

Mooney Mite Series M-13
Service Bulletin No. 14

Purpose:

The purpose of this Bulletin is to provide information on the allowable free play of the tail surfaces of the subject model aircraft and such other information concerning bushing wear, etc., as is necessary to correct an unsatisfactory condition found on several airplanes, which if allowed to continue, could perhaps result in a dangerous situation.

Serial Number Affected

<u>Model</u>	<u>Serials</u>
M-18L	2 to 82
M-18C	201 to 322
M-18LA	101 to 145
M-18C 55	323 to 357

Allowable Free Play Limits

The following sketch illustrates the maximum allowable free play at the specified points.

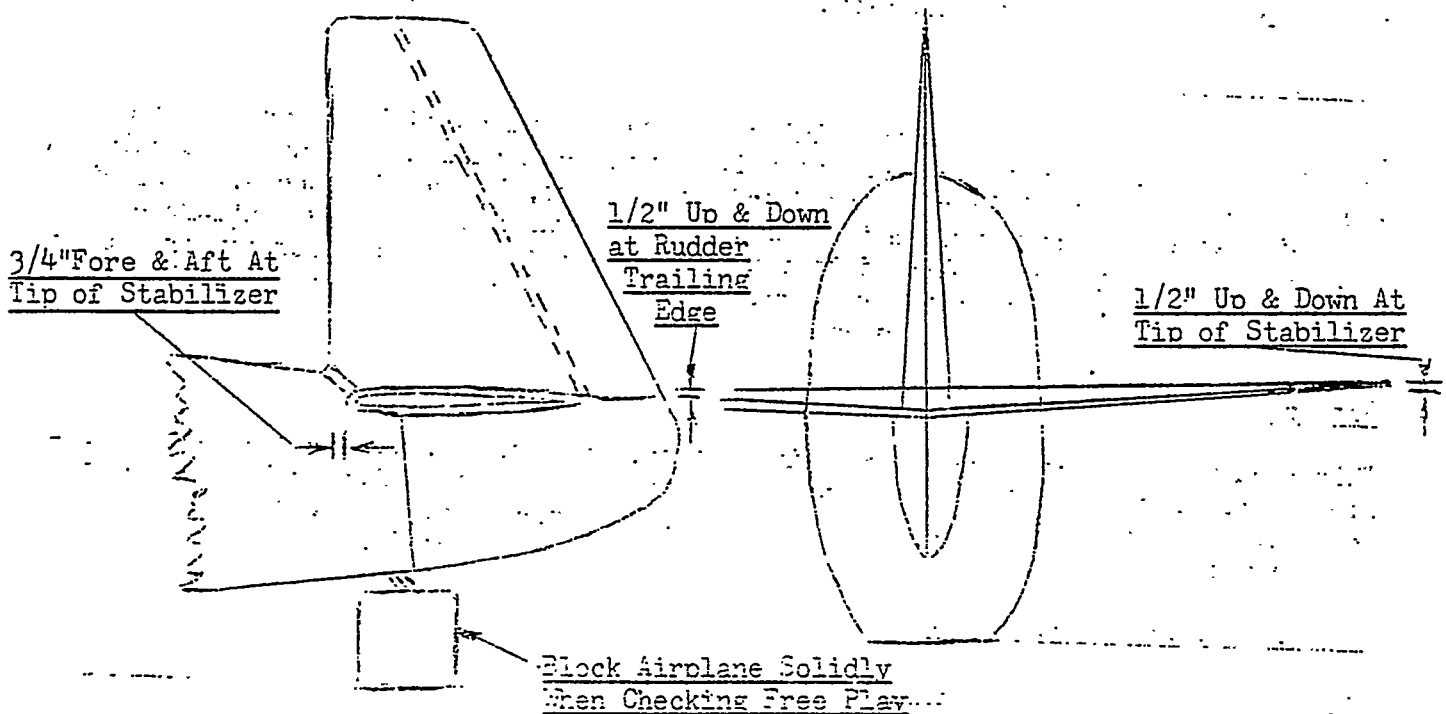

When checking stabilizer tip free play, either fore and aft or up and down, measure free play on the opposite tip from where the stabilizer is moved by application of hand pressure. This eliminates errors in measuring due to bending deflections of the stabilizer itself.

Mooney Mite Series M-18
Service Bulletin No. 14
(Continued)

Procedure

First inspect all tail surface joints and attachment bolts for tightness. All Bolts Should Be Tight, since bushings are intended to take the wear. If any bolt is loose, inspect for wear, and replace if necessary, using washers if required, and make sure all bolts are tight. Then block tail of airplane solidly and check free play as indicated by sketch.

If dimensions are within limits, there is nothing further to be done, except to be sure in the future to see that bolts are tight and free play limits are not exceeded at regular periodical airplane inspections.

If any or all of free play limits are exceeded, find which joint or joints seem to have most play and replace bushings until free play is within limits. In this connection, the up and down free play at the rudder root trailing edge is also affected by wear in the adjustable stabilizer trim system, particularly for the Model M-18L, where the 886 screwjack, located at the rear fuselage bulkhead, may exhibit excessive end play. In this case, either replace or rework the screwjack to eliminate the excessive end play.

General Notes

In most cases if play exceeds the limits it will be found that bolts are loose or have been loose, allowing wear on the bolts or attaching lugs. The main attaching bolts through the stabilizer may be found to be loose, in some instances. Replacing the main attachment bushings on the earlier models which did not have anti-friction bearings and getting all bolts tight usually will bring the stabilizer tip free play within the limits. If bushings or parts such as the screwjack are needed, they are readily obtainable from the factory.

Summary

This required inspection and corrective action, if required, will prevent any possible trouble resulting from excessive free play at the tail surfaces of the subject models. The information provided also serves as future service and inspection data for personnel responsible for the maintenance of these aircraft.

Bearing And Screwjack Summary

<u>Model</u>	<u>M-18L</u>	<u>M-18C</u>	<u>M-18LA</u>	<u>M-18C 55</u>
Plain Mounting Bushings	2 to 82	201 to 277	101 to 135	-
Needle Mounting Bearings	-	278 to 322	136 to 145	323 to 357
P/I 886 Screwjack*	2 to 82	-	-	-

*Supply Drawing 886 to owners of M-18L airplanes.

ORIGINAL
As Received By
ATP

MOONEY AIRCRAFT, INC.
M-18 SERVICE LETTER NO. 15

DATE: 7-13-59
SUBJECT: General Inspection and Maintenance
MODELS AFFECTED: M-18 All Serial Numbers

INTRODUCTION:

Several cases of wood deterioration have been reported on M-18 aircraft. The most serious damage has occurred in the center section of the wing due to water which probably enters through the cockpit canopy and the wing fuselage joint. In view of this, the following inspection is recommended as soon as practical and at subsequent annual inspections.

INSTRUCTIONS:

- (1) Remove seat, auxiliary fuel tank and belly access panel.
- (2) Inspect ribs, skin, and spars at lower center section and around fuselage fittings.
- (3) Inspect wood in wheel well area.
- (4) Inspect tail cone in area of baggage compartment.
- (5) All belly skin panels (wing and fuselage) between spars, ribs, and stiffeners should have a 1/4" diameter hole in the lowest corner. Add these holes if they do not exist.
- (6) Check and clean all drain holes in wing, fuselage, and empennage.
- (7) Inspect all other open and accessible wood areas on airplane. It is recommended that a water resistant cloth or plastic adhesive tape be applied at the wing to fuselage joint from the wing leading edge to the wing trailing edge, under the metal fairing strip to prevent the entry of water at this point.
- (8) A few reports have been received concerning looseness and/or cracks at the rear-most fuselage bulkhead and attachment blocks on the stabilizer spar. Inspect rear bulkhead for cracks and security of attachment in the area of the stabilizer attachments. Inspect attachment blocks for cracks or looseness at spar.

LANDING GEAR RIGGING

To check the rigging of the landing gear the weight of the aircraft must be removed from the system.

Elevate the aircraft on three suitable saw-horses. Two of which are placed under the wing just outboard of each main gear, between the third and fourth ribs, approximately three feet from the fuselage skin. The saw-horses should be of sufficient length to extend from slightly behind the rear spar to the front spar, and preferably past the leading edge of the wing. This length is desired to minimize damage to flaps and skin on the leading edge should the aircraft accidentally be rolled back or forward on the front spar while elevated on the horses. Should the tail be pushed down too far, a saw-horse extended behind the rear spar would rupture the flap fabric. Should the nose drop, rolling the aircraft onto the leading edge, the end of a saw-horse that did not extend beyond the spar would be pushed thru the leading edge skin. See Sketch A for elevation details.

To step on the wing walk or enter the cockpit while the aircraft is elevated will naturally cause the nose to drop. This is prevented by placing the third saw-horse under the rear bulkhead of the fuselage and weighing down the empannage. Either by tying ballast to the tail bumper or placing it inboard on the stabilizer spar and on top of the fuselage just in front of the fin.

1. INSPECTION:

It has been found absolutely necessary for the over-center locks to be in the over-center position and that considerable force is required to change this position. To check whether lock is over center lay a short straight edge along the top side of the lock as shown in Sketch B.

When the straight edge and link are parallel the lock is over center. The locks are held in this position by the force required to place the retracting lever in the "Gear Down" position. On new airplanes or ones in which new parts are installed the force at the top of the lever with the main gears disconnected from the retracting truss on which the lever is mounted should be 18 to 24 lbs. The force should be 2 lbs. additional with all three gears connected. The nose gear should be checked alone first, on which greater or less force is controlled by adding or removing washers on the forward side of the handle lock down plate as shown in Sketch C.

When checking the main gears a greater force is obtained by lengthening and less force by shortening the push-pull tubes operating these gears. This is done by adjusting the end fittings in the push-pull tubes at the nose gear retracting truss.

2. RIGGING

With all gears down and main gears disconnected from retracting truss, position lock down plate with washers as described before to obtain recommended force to push retracting handle into the lock down plate, making sure that nose gear is securely locked.

Hook-up main gear linkage, adjusting so that proper force is obtained and making sure that main gears are securely locked. Whether the gears completely retract or not, precedence should be given to the gears locking down properly.

ORIGINAL
As Received By
ATP

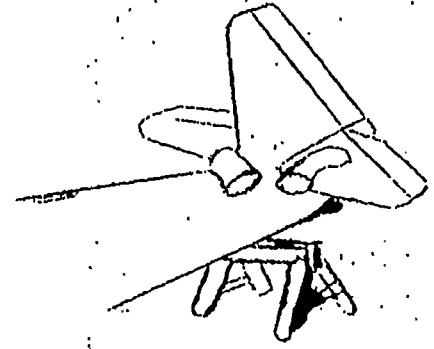
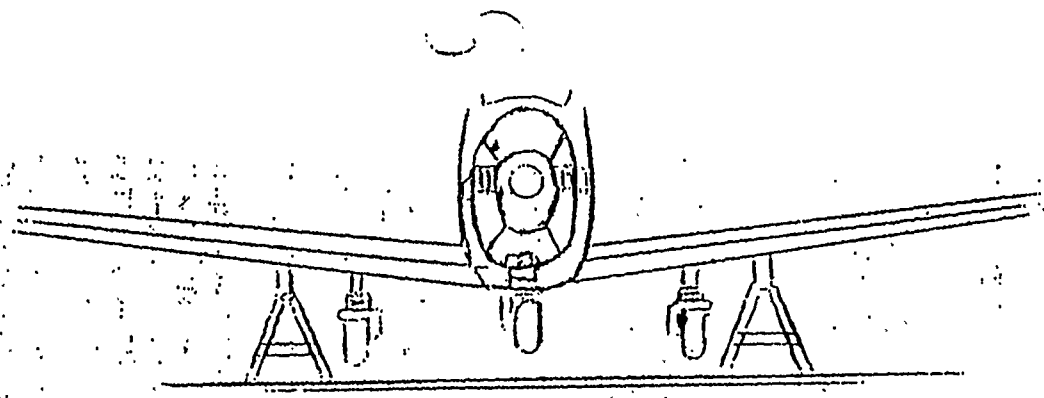

Sketch A

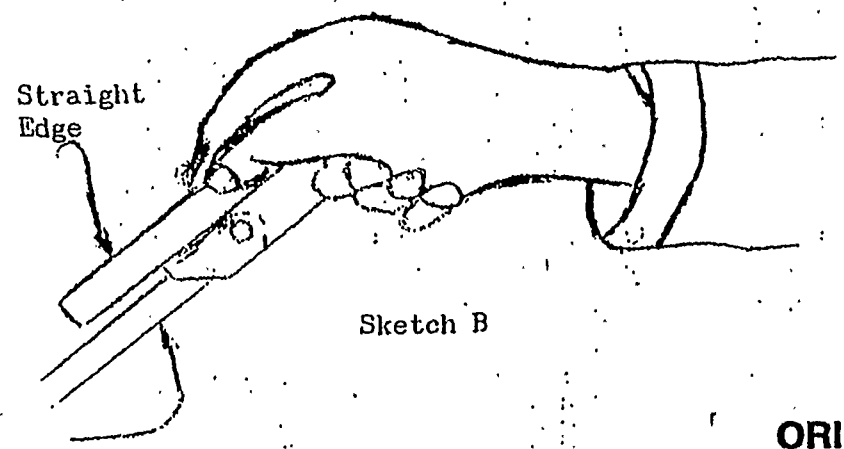

Straight Edge

Sketch B

Link

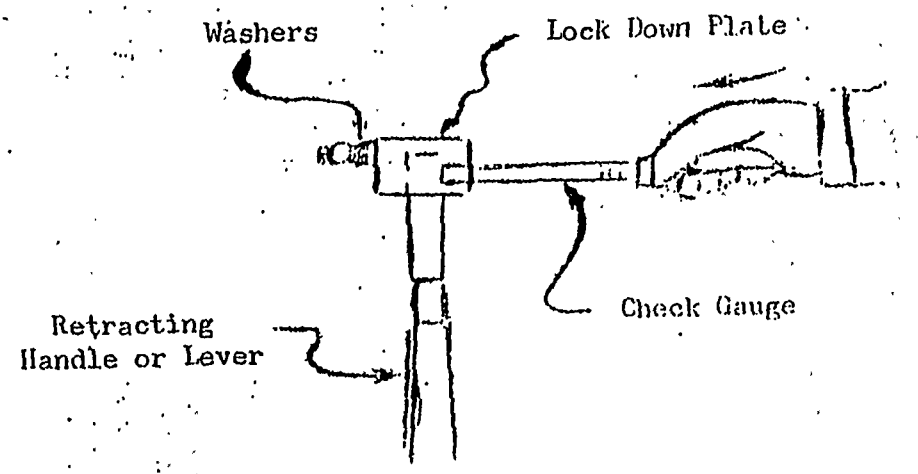

Washers

Lock Down Plate

Retracting Handle or Lever

Check Gauge

Sketch C

**ORIGINAL
As Received By
ATP**

MOONEY AIRCRAFT, INC.

M-18 SERVICE LETTER NO. 16

(This Service Letter is F. A. A. Approved)

DATE: October 16, 1959
SUBJECT: General Inspection and Rework
MODELS AFFECTED: All M-18 Series Aircraft
TIME OF COMPLIANCE: Within the next 10 flight hours but not later than 11-15-59

INTRODUCTION:

Several cases of wood and glue joint deterioration have been reported on M-18 aircraft. Instances have been reported of cracks in the horizontal stabilizer spar and loosening of the attach blocks on this spar. It is therefore recommended that (1) care be exercised in future inspection and maintenance and (2) that care be exercised during ground handling of the aircraft so that the horizontal stabilizer will not be damaged. In view of the findings of an investigation of a recent accident involving an M-18, it is mandatory that the following inspection and rework be accomplished.

INSPECTION:

Part A - Empennage

1. Remove and completely disassemble empennage. Remove control surfaces and hinges from fin and horizontal stabilizer. Separate fin, horizontal stabilizer and tail truss. Remove bolts thru attach blocks on horizontal stabilizer spar.
2. Inspect all bolted joints for the following items: (a) wear on bolt, (b) wear on bolt hole in fittings and lugs, (c) wear on bushing and (d) wear of bushing on fittings, lugs, and wood. Replace parts as necessary.
3. Remove all fabric from horizontal stabilizer and fin. Inspect all wood and glue joints including attachment of leading edge skin to spar for deterioration.
4. At center section of horizontal stabilizer spar inspect glue joint between attach blocks and spar for deterioration and inspect spar and blocks for cracks. Inspect fin spar for cracks at attach bolt bushings.
5. Any defective wood parts shall be replaced or repaired in accordance with Civil Aeronautics Manual 18 and/or manufacturers recommendations. When it is determined that the fin and horizontal stabilizer are in satisfactory condition, the rework shown in Figures 1 and 2 shall be accomplished. The glue used shall be a urea-formaldehyde type such as Melwood or Cascamite. Parts for the required rework are available at no cost. Order Kit 5118-16 from the Spare Parts Department of Mooney Aircraft, Inc.
6. When recovering make fabric continuous under four outboard hinges on horizontal stabilizer and two upper hinges on fin. See that all drain holes are located as shown in Figure 3 and that they are clear.
7. Inspect welds at rudder and elevator hinges and control horns and at all joints on tail truss for adequacy of weld and for cracks, using either of the following methods: (a) magnetic particle or X-ray inspection or (b) remove paint and primer and visually inspect welds with a 10 power glass. Parts with defective welds are to be replaced or repaired. A joint may be re-welded providing the old weld is removed and the surface thoroughly cleaned.

8. Remove upper tail truss attach fittings from rear tail cone bulkhead and inspect as described in Item 2. Inspect bulkhead front and back for cracks in area of these fittings. Inspect bulkhead for separation between web and core. Check glue joint between bulkhead and tail cone skin. Repair in accordance with M-18 Service Letter No. 17. Examine trim linkage and its attachment to the lower part of rear bulkhead for excessive play. Replace worn parts as necessary.
9. Reassemble and install empennage making sure all bolts are tight. Block airplane solidly at tail skid and inspect for empennage play as follows: (See Figure 4)
 - (a) Horizontal stabilizer - move up and down at one tip and measure at opposite tip - total allowable play 1/2 inch up and down
 - (b) Horizontal stabilizer - move fore and aft at one tip and measure at opposite tip - total allowable play 3/4 inch fore and aft
 - (c) Fin - move fore and aft at top of leading edge and measure at bottom of rudder trailing edge - total allowable play 1/2 inch up and down

Part B - Fuselage (Tail Cone)

1. Inspect around steel fuselage fittings and drain holes for wood deterioration. See that all drain holes are located as shown in Figure 5 and that they are clear. Inspect all glue joints for deterioration.

Part C - Wing

1. Remove seat, auxiliary fuel tank, and belly access panel. Inspect ribs, skin, and both spars at lower center section and around fuselage fittings for wood and glue joint deterioration.
2. Inspect all wood and glue joints in wheel well area for deterioration. Examine both spars for cracks in area of gear attachments.
3. Inspect interior condition of wing in areas having access openings.
4. Remove aileron and inspect hinges and control horn as required for rudder and elevator in Part A, Item 7, of this Service Letter.
5. Remove wing fabric locally in area of aileron hinges and at inboard corner of aileron well and check condition of wood and glue joints. If evidence of deterioration is found, remove fabric further as necessary for complete examination on forward side of wing trailing edge. Check security of attachment of wing trailing edge in aileron area.
6. See that all drain holes are located as shown in Figure 6 and that they are clear.
7. Add a strip of water resistant cloth or plastic adhesive tape at the wing to fuselage joint (both sides) from the wing leading edge to the wing trailing edge under the metal fairing strip on both sides of the airplane. This tape strip should form an angle with one leg attached to the fuselage and one to the wing in order to prevent the entry of water at this point.

Part D - Control Systems

1. Inspect control systems (aileron, trim, rudder, and elevator) as follows:
 - visually inspect all welds for cracks and adequacy of weld.
 - check security of all bolted hinge and fitting attach points.

Figure 1

- AN 3-20A (2)
- AN 970-3 (2) Front Face of Spar
- AN 960-10 (4)
- AN 365-1032 (2)

- AN 3-20A
- AN 970-3 (2)
- AN 960-10 (2)
- AN 365-1032

On Assembly of Stabilizer to Fin

1301 -
Glue to Rear Face of Stabilizer Spar. Trim ends if Necessary to Fit Between Glue Elocks.

735-3 Gusset (Ref.)
Dotted for Clarity

Fin Spar (Ref.)

(Upper Surface)

Stabilizer Spar (Ref.)

- AN 3-15A (2)
- AN 970-3 (2)
- AN 960-10 (2)
- AN 365-1032 (2)

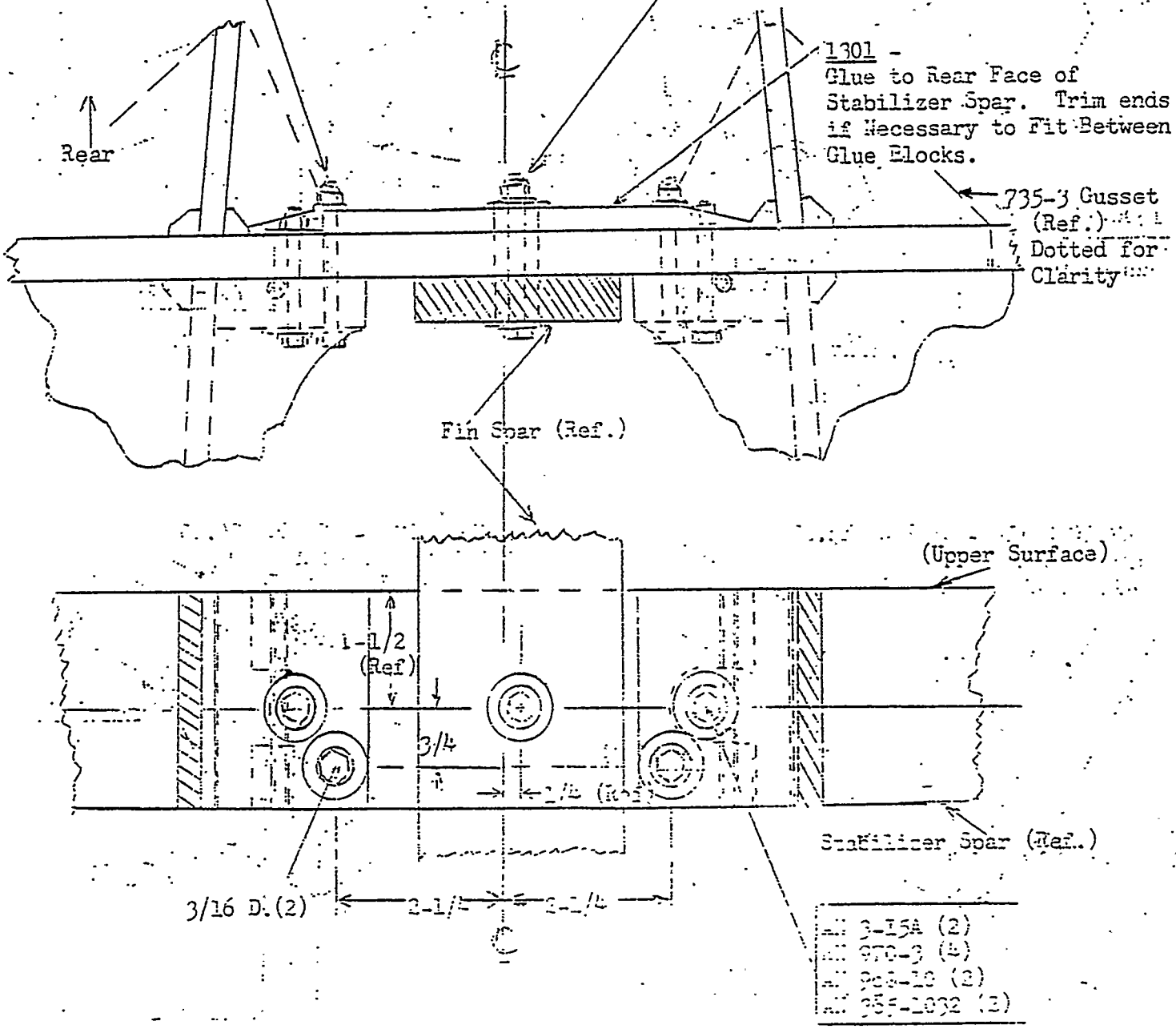

ORIGINAL
As Received By
ATP

STABILIZER - STATION 16.375
TRAILING EDGE GUSSET AND GLUE
BLOCK INSTALLATION

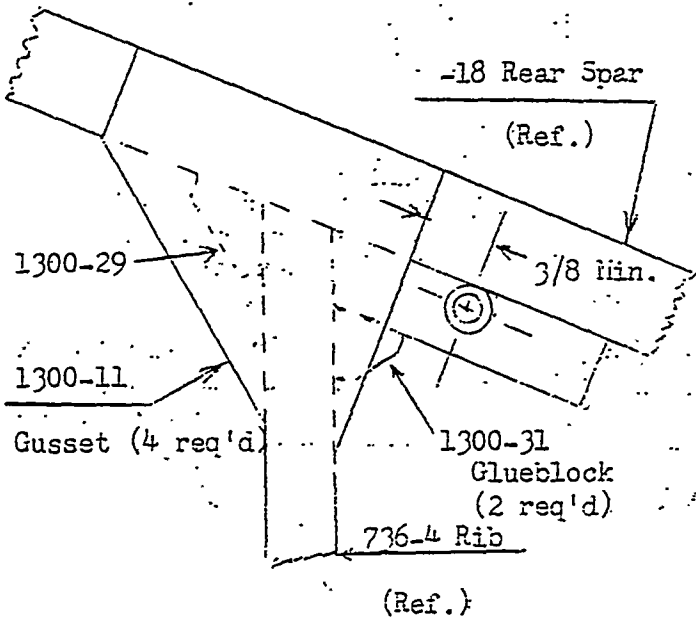

STABILIZER - STATION 32.75
TRAILING EDGE GUSSET AND GLUE
BLOCK INSTALLATION

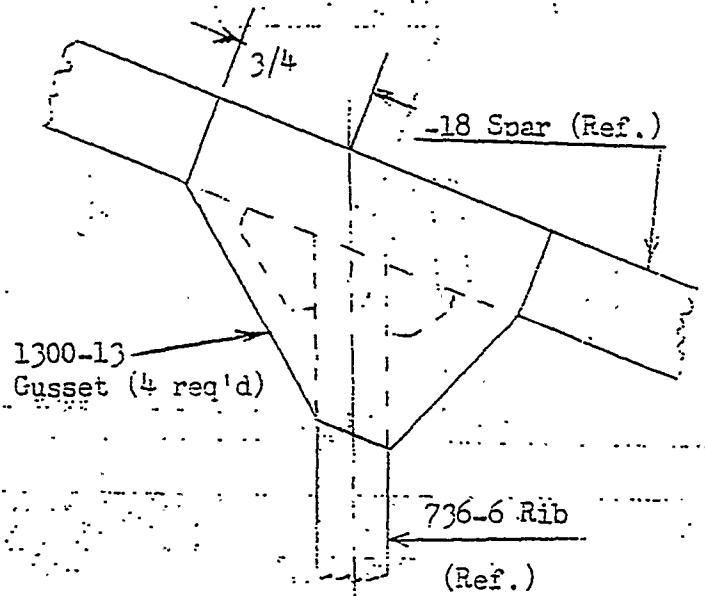

VERTICAL FIN - STATION 13.00
TRAILING EDGE GUSSET AND
GLUE BLOCK INSTALLATION

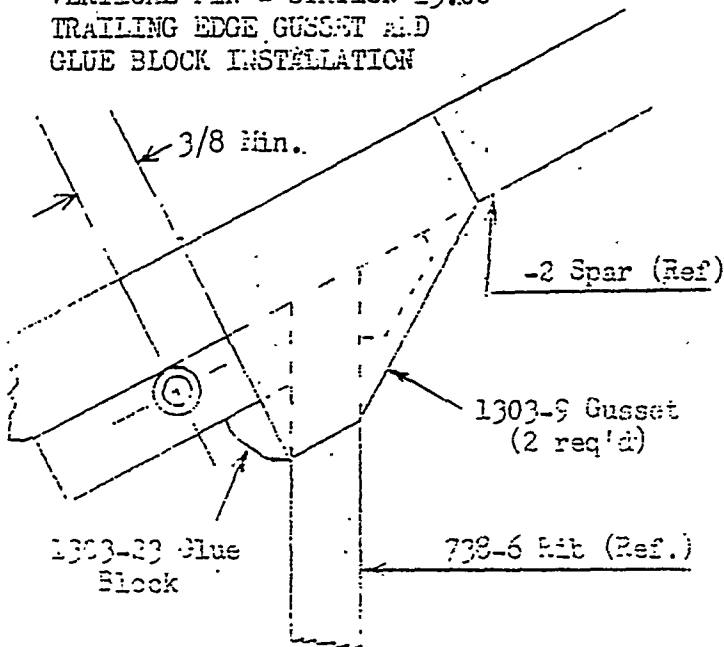

VERTICAL FIN - STATION 25.25
TRAILING EDGE GUSSET AND
GLUE BLOCK INSTALLATION

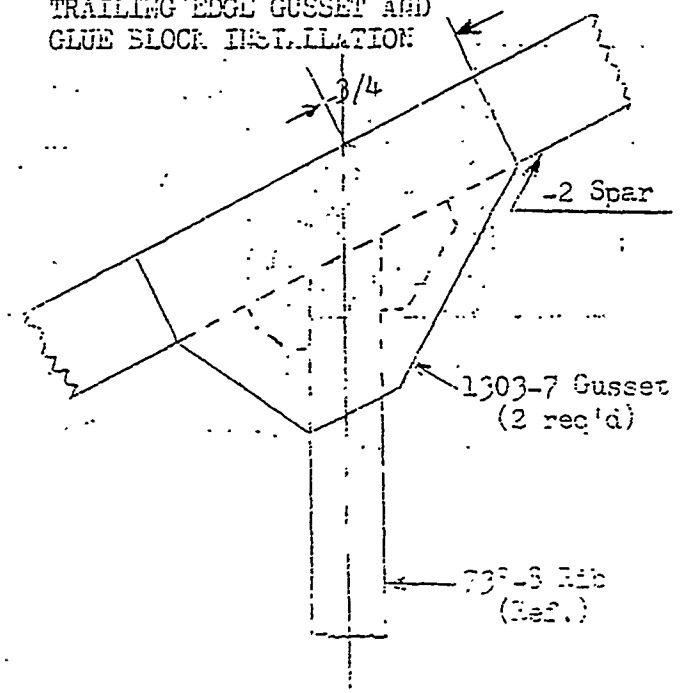

ORIGINAL
As Received By
ATP

Figure 3

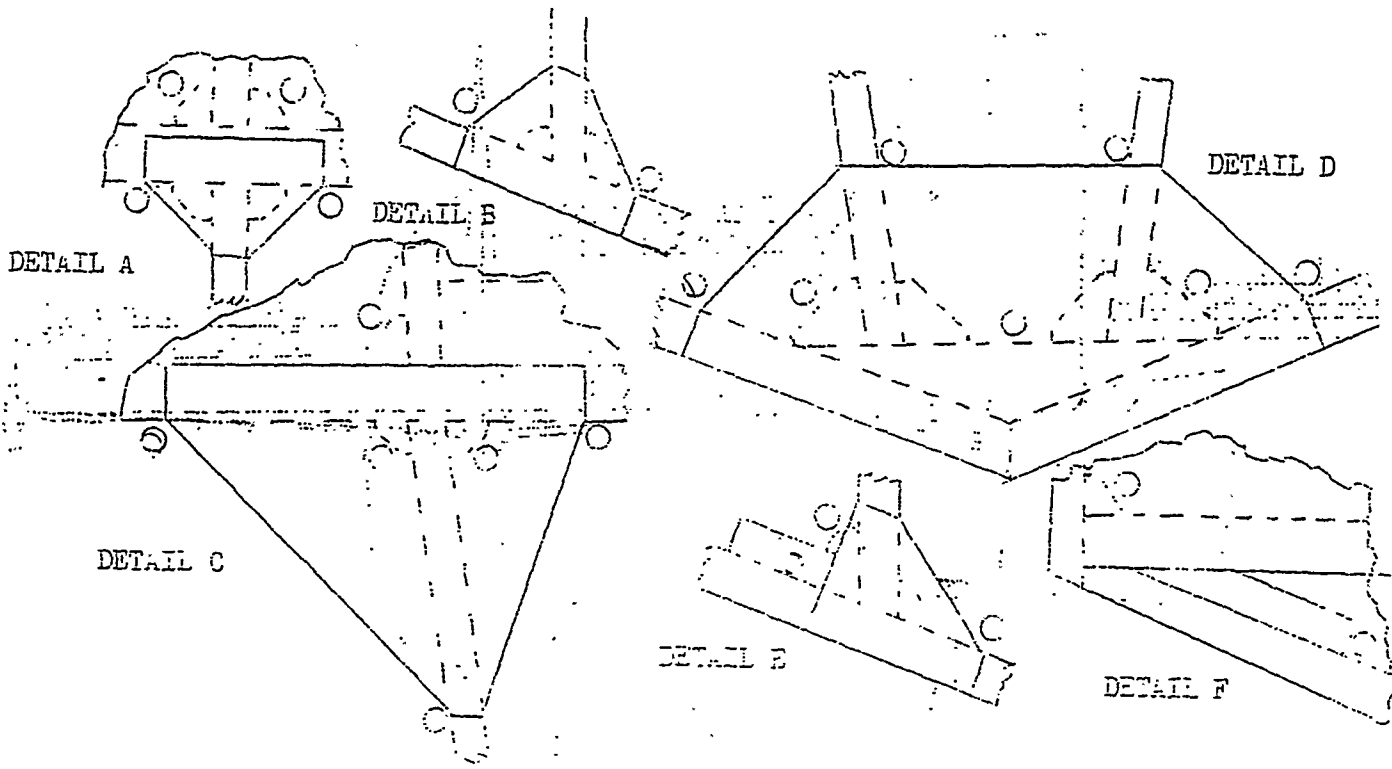
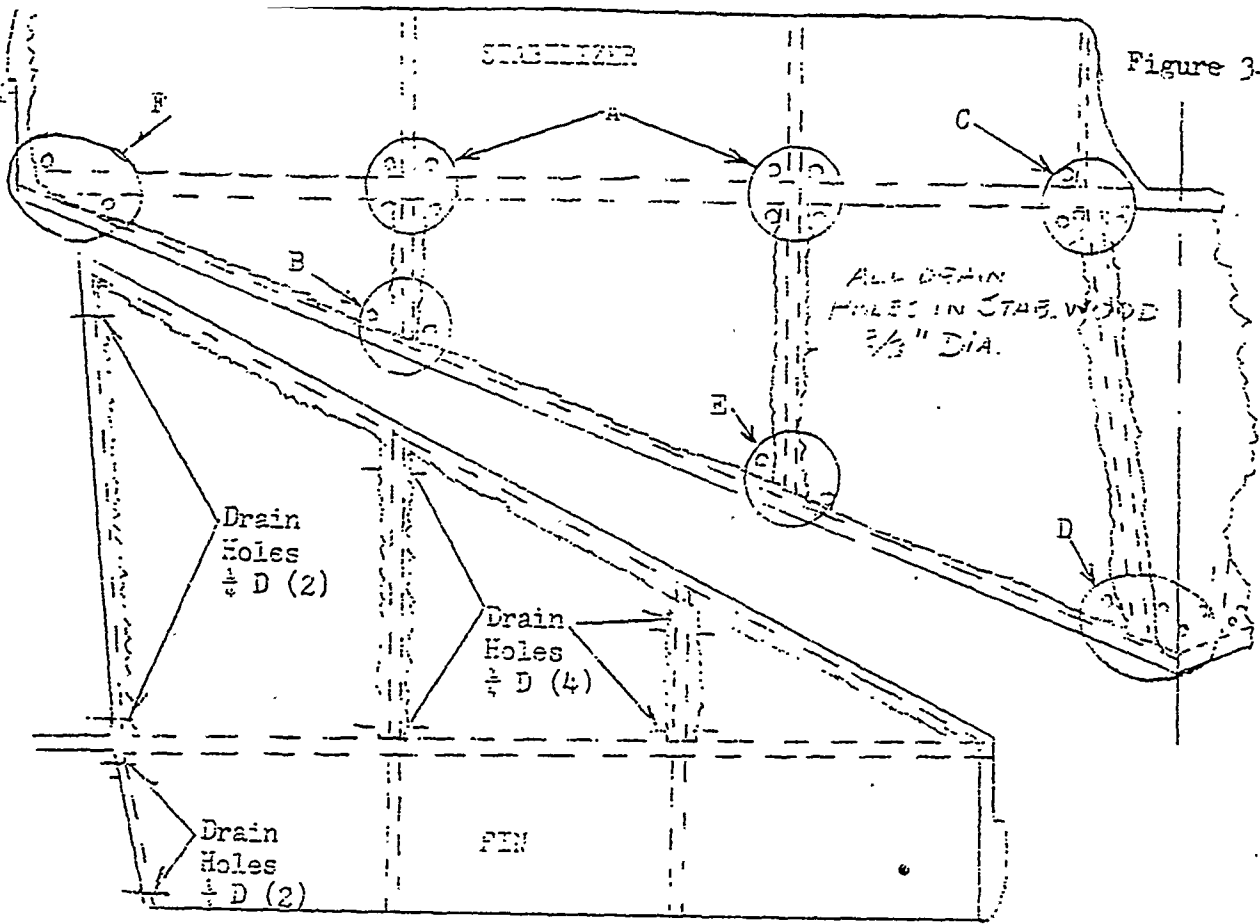

NOTE

- 1) Use all 331-B Grommets on Fabric over all drain holes in Stabilizer and Pin Body Kit.
- 2) Drill Pin Inlets in Ribs and clear hole in Body Kit after Fabric Installation.
- 3) Exercise care in drilling Drain Holes so as not to damage adjacent structure.

ORIGINAL
As Received By
ATP

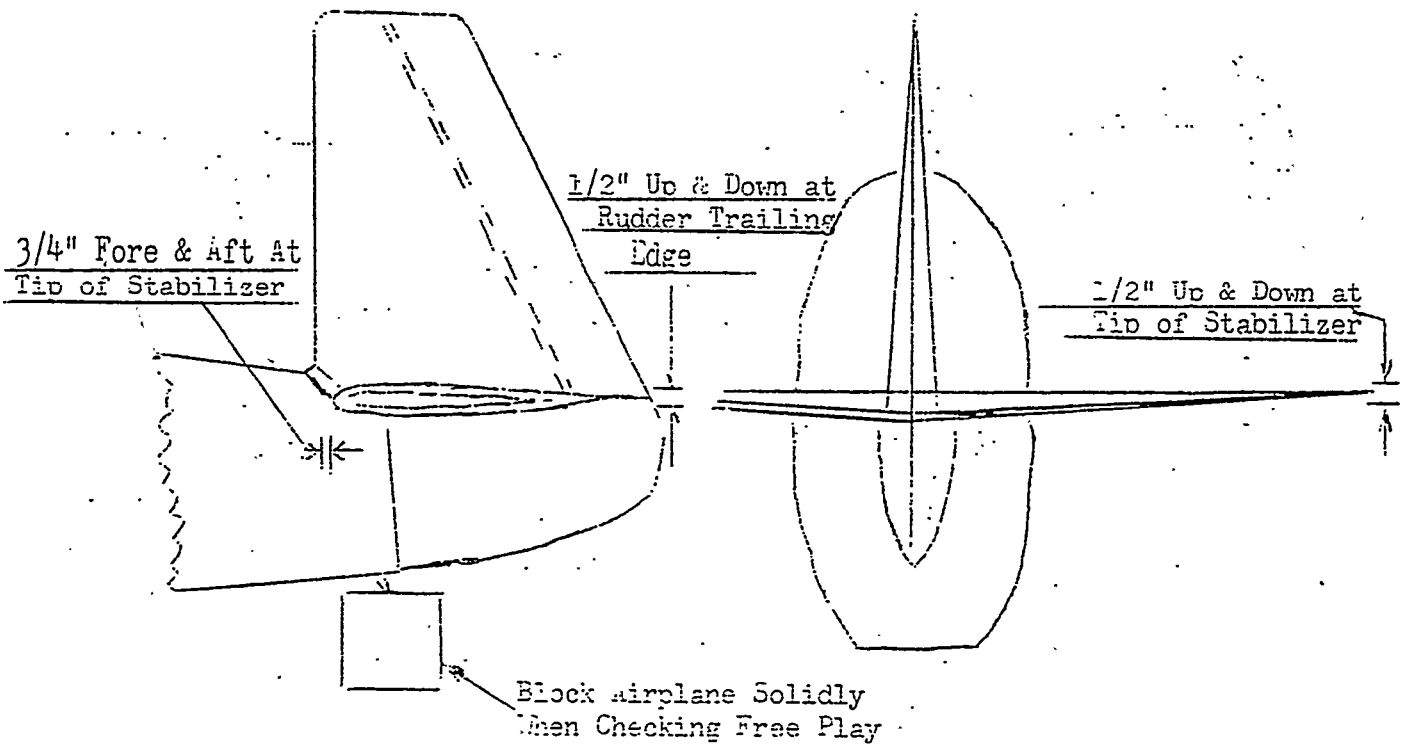

ORIGINAL
As Received By
ATP

Figure 5

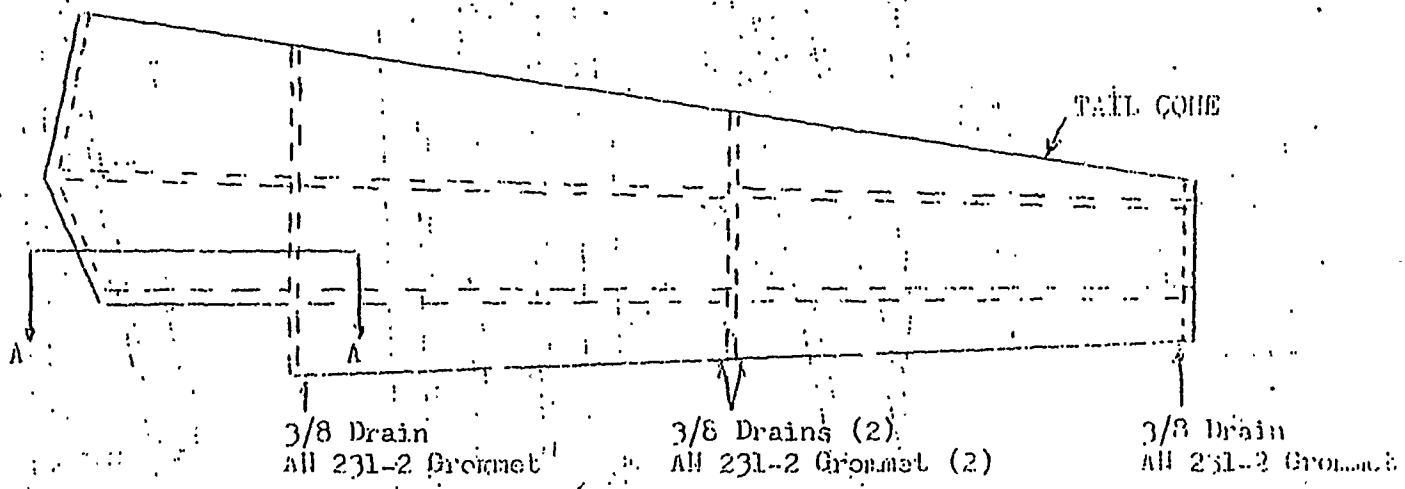

DRAIN HOLES AT C OF FUSELAGE

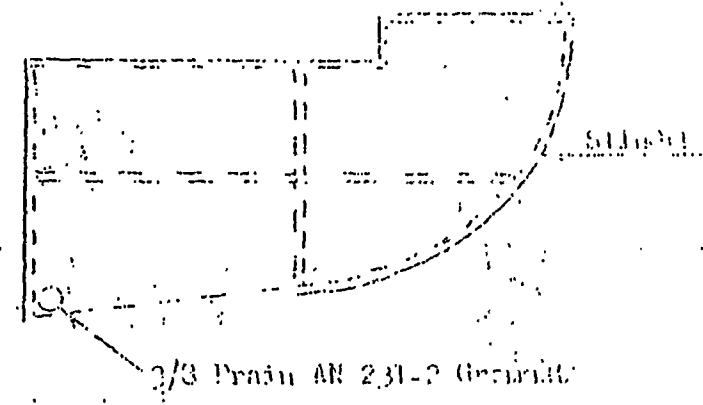
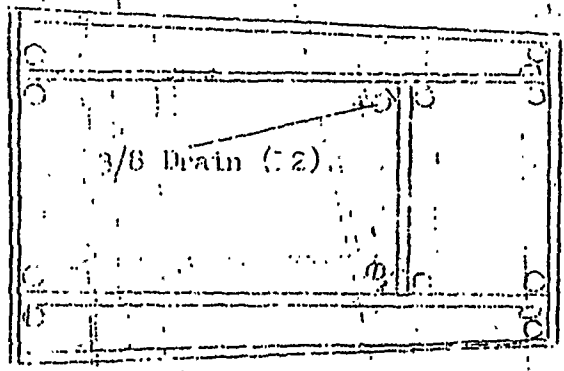

ORIGINAL
As Received By
ATP

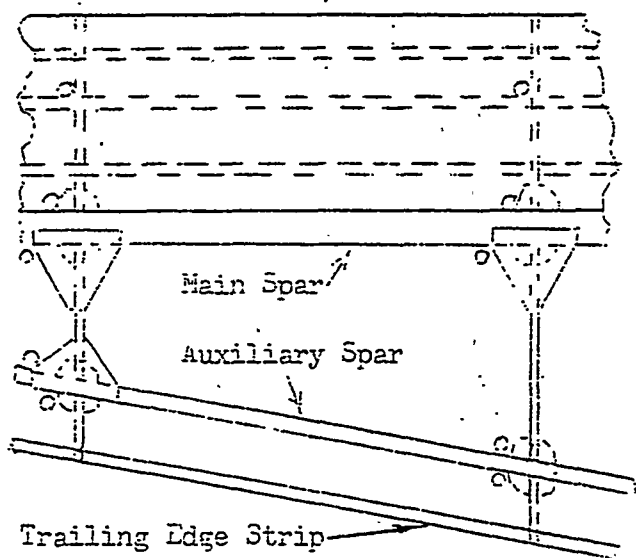
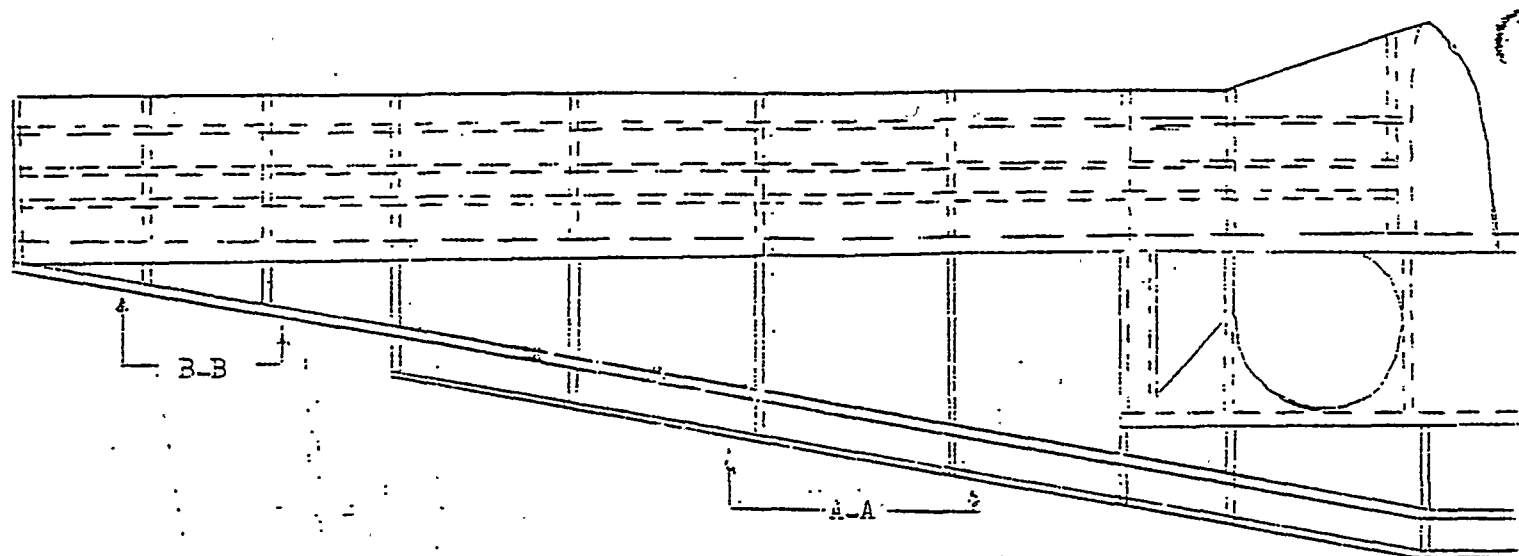

Section A-A
Typical Station 0-112

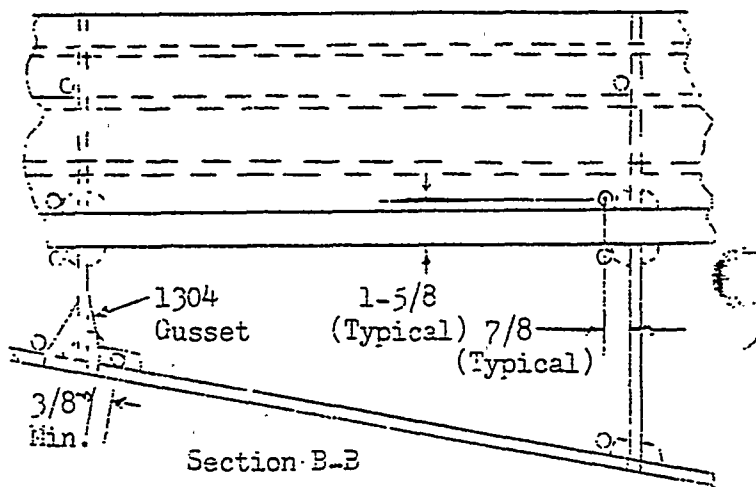

Section B-B

Typical Station 112-160.5

NOTE

- 1) Use All 231-1 Grommets over all Drain Holes - All Drain Holes $3/8$ diameter.
- 2) If Aileron Hinge Attachment is found loose, it is recommended that Gusset P/N 1304 be installed top and bottom at Station 148 from auxiliary Spar to Trailing Edge Rib. Distance from center of Aileron Hinge Mount Hole to Gusset no less than $3/8$ inch.
- 3) Exercise care in drilling Drain holes so as not to damage adjacent structure.

ORIGINAL
As Received By
ATP

INSPECTION REPORT

Please complete and return this form to Mooney Aircraft, Inc., P. O. Box 72, Kerrville, Texas.

M-18 Service Letter 16 has been complied with on the following airplane:

Registration Number _____

Total Hours on Airplane _____

Each paragraph below refers directly by number to an item in the Inspection Instructions in M-18 Service Letter No. 16. Each paragraph below carries a blank for hours on each group of parts inspected. This is done in case the parts in question have been replaced or undergone major rework in the area inspected. If this time is the same as that on the airplane state same. If not, state time since replacement or major rework and indicate in space following hours what work was done.

Your cooperation in completing and returning this form will be greatly appreciated.

Please state condition of parts in blanks. If more space is needed, please add note.

1. Part A-2. Hours _____

a) bolts _____

b) bushings _____

c) fitting and lugs _____

d) wood _____

2. Part A-3. Hours _____

a) wood _____

b) glue joints at corner blocks and gussets _____

c) glue joints attaching leading edge skin _____

3. Part A-4. Hours _____

a) glue joint at attach block _____

b) spar at center section _____

4. Part A-7. Hours _____

a) tail cross webs _____

b) control horn webs _____

c) control range webs _____

5. Part A-8. Hours _____

c) trim linkage and attachment _____

6. Part A-9. Hours _____
Record play at:

- a) horizontal stabilizer, up and down _____
- b) horizontal stabilizer, fore and aft _____
- c) bottom of rudder, up and down _____

7. Part B-1. Hours _____

- a) wood at fittings _____
- b) wood at drain holes _____
- c) glue joints _____

8. Part C-1. Hours _____

- a) wood _____
- b) glue joints _____

9. Part C-2. Hours _____

- a) wood _____
- b) glue joints _____
- c) spar at gear fittings _____

10. Part C-3. Hours _____

- a) wood _____
- b) glue joints _____

11. Part C-4. Hours _____

- a) control horn weld _____
- b) control hinge weld _____

12. Part C-5. Hours _____

- a) wood _____
- b) glue joints _____

13. Part C-1. Hours _____

- a) welds _____
- b) bolted points _____

MOONEY AIRCRAFT, INC.

M-18 SERVICE LETTER NO. (17)

(This Service Letter is FAA Approved)

DATE: OCTOBER 24, 1959
SUBJECT: REAR BULKHEAD REINFORCEMENT
MODELS AFFECTED: NOTED
TIME OF COMPLIANCE: IN CONJUNCTION WITH MOONEY M-18 SERVICE LETTER NO. 16

PARTS LIST:
Kit #1, P/W 1310 Block (1)
Kit #2, P/W 1307 Plate (Front) (1)
P/W 1308 Plate (Rear) (1)
P/W 1309-7/-8 Fittings (1 ea.)
Kit #3, P/W 1307 Plate (Front) (1)
P/W 1308 Plate (Rear) (1)
P/W 1314-7/-8 Clips (Upper) (1 ea.)
P/W 1315-7/-8 Clips (Lower) (1 ea.)

INTRODUCTION

Reports involving M-18 aircraft manufactured prior to 1953 have been received concerning the following defects in the rear-most bulkhead.

Loose glue joint between bulkhead and tail cone skin at top of bulkhead.

- 2) Separation of plywood web and spruce core.
- 3) Cracks of plywood web and/or spruce core in the area of the empennage attachment brackets.

This rear bulkhead area should be carefully inspected (see M-18 Service Letter No. 16, Item A-8) with particular attention to the items listed above on all M-18 aircraft including those manufactured from 1953 on. These later aircraft had clips (P/W 1157-1/-2) attached to the upper longerons (on top) which picked up the upper bolt through the empennage attachment bracket.

The rework described below is divided into parts with the airplanes affected listed in Item 1 of each part. Parts for the required rework are available at no cost.

PART A

1. All airplanes having the defect described in Item 1 of the Introduction are to be repaired in accordance with Figure 1 or Figure 2 depending on the type of elevator control system.
2. Order Rework Kit SL 18-17-1.

PART B

1. All airplanes not having P/W 1157-1/-2 clips installed and all airplanes having the defects described in Items 2 or 3 of the Introduction are to be repaired as follows:

ORIGINAL
As Received By
ATP

- a. Remove the following items from bulkhead:
 - i. Elevator bellcrank bracket
 - ii. Lead ballast weight if installed
 - iii. Longeron clips P/N 1157-1/-2 (if installed) by removing bolt through upper longeron
- b. Clean excess paint or glue off faces of bulkhead so that plates bear on flat surface.
- c. Attach P/N 1307 and 1308 plates to bulkhead using AN3 bolts through the tail attachment holes, elevator bellcrank bracket and holes, and lead ballast and holes. NOTICE - Do not reassemble tail attachment brackets at this stage.
- d. Using P/N 1308 as template drill 3/16 diameter holes (10) through bulkhead and P/N 1307. Exercise care to drill holes perpendicular to bulkhead. Install AN3 bolts specified in Figure 3 for attachment of elevator bellcrank bracket, lead ballast, and through holes drilled. Exercise care in tightening bolts so as not to crush bulkhead.

PART C

1. For all airplanes not having P/N 1157-1/-2 clips installed, the following must be accomplished after compliance with Part B:
 - a. Mark the location on the outside of tail cone of the four holes through the upper longeron as shown on Figure 4.
 - b. Drill one of the holes on each side with a 1/16 diameter drill perpendicular to skin. Examine the inner face of the longerons. The holes should be in the center of the longeron. If the hole is off-center, correct the error as much as the original hole will allow by re-drilling with a 1/8 diameter drill. Applying the same correction, drill the other two holes with a 1/8 diameter drill.
 - c. Install P/N 1309-7/-8 fittings, empennage attachment brackets and cable guides as shown in Figure 4.
 - d. Block fittings to prevent play and, using 1/8 diameter holes as guides, drill 11/64 diameter holes (4) through longerons and 1309 fittings. Using 11/64 diameter holes as guides, drill out holes to 3/16 diameter.
 - e. Bolt the 1309-7/-8 fittings to the longerons as shown in Figure 4. Exercise care in tightening bolts so as not to crush wood.

PART D

1. For airplanes which had P/N 1157-1/-2 clips installed and which have been reworked in accordance with Part E, the following shall be accomplished:
 - a. Reinstall empennage attachment brackets and cable guides and replace P/N 1157-1/-2 clips with P/N 1314-7/-8 clips and add P/N 1315-7/-8 clips on lower side of upper longeron picking up lower bolt of empennage attachment brackets as shown in Figure 5. Install vertical bolt through two clips and longeron as shown.

PART E

All airplanes having been reworked according to Part B shall have the following accomplished:

- a. Reinstall empennage and check for empennage play (see M-18 Service Letter No. 16, Item A-9).
- b. The elevator control system shall be adjusted as necessary to correct for the addition of .051 thick plates to bulkhead. In adjusting heim bearings (1 to 2 turns) exercise care that the end of the threaded shank is not pulled out past the inspection hole on the side of the female threaded rod end.
 - (1) Remove forward access panel on the right hand side of the airplane for access to elevator control system linkage.
 - (2) With stabilizer in approximately level position, set control stick in neutral position (perpendicular to horizontal reference).
 - (3) For airplanes which feature a cable control elevator system forward of the rear bulkhead, the adjustment of the elevators is done by adjusting turnbuckles (take up on one and unscrew the other) until elevators are in a neutral position while maintaining control stick in approximately neutral position.
 - (4) For airplanes which feature a push-pull rod elevator control system forward of the rear bulkhead, the adjustment of the elevators is done by adjustment of the heim bearing at either the rear or the front of the push-pull rod in the tail cone until the elevators are level with the stabilizer with the control stick in the neutral position.
- c. The trim control system shall be adjusted as described below so as to have the correct angular travel after installation of P/N 1307 and 1308 plates.
 - (1) Level airplane until front face of main wing spar is perpendicular to horizontal reference. Pull seat forward for access to spar.
 - (2) Set trim control to "nose up" position.
 - (3) For airplanes equipped with a cable control trim system, the adjustment is made as follows:
 - i. Remove chain from screwjack by removing bolt connecting sprocket chain to cable on one side. See Figure 6.
 - ii. Turn screwjack at sprocket until the leading edge of vertical fin is inclined forward 3.5° to vertical reference.
 - iii. Reinstall chain around sprocket and connecting bolt to cable end.
 - iv. Check "nose down" trim position for vertical fin leading edge inclination rearward of 1.5° to vertical reference.
 - (4) For airplanes equipped with push-pull rod trim control system forward of the rear bulkhead, the adjustment is made as follows:
 - i. Adjust heim bearing of trim adjustment link shown in Figure 7 until leading edge of vertical fin is inclined forward 3.5° with trim setting in "nose up" position.
 - ii. Check inclination of leading edge of vertical fin for 1.5° rearward for trim in "nose down" position.

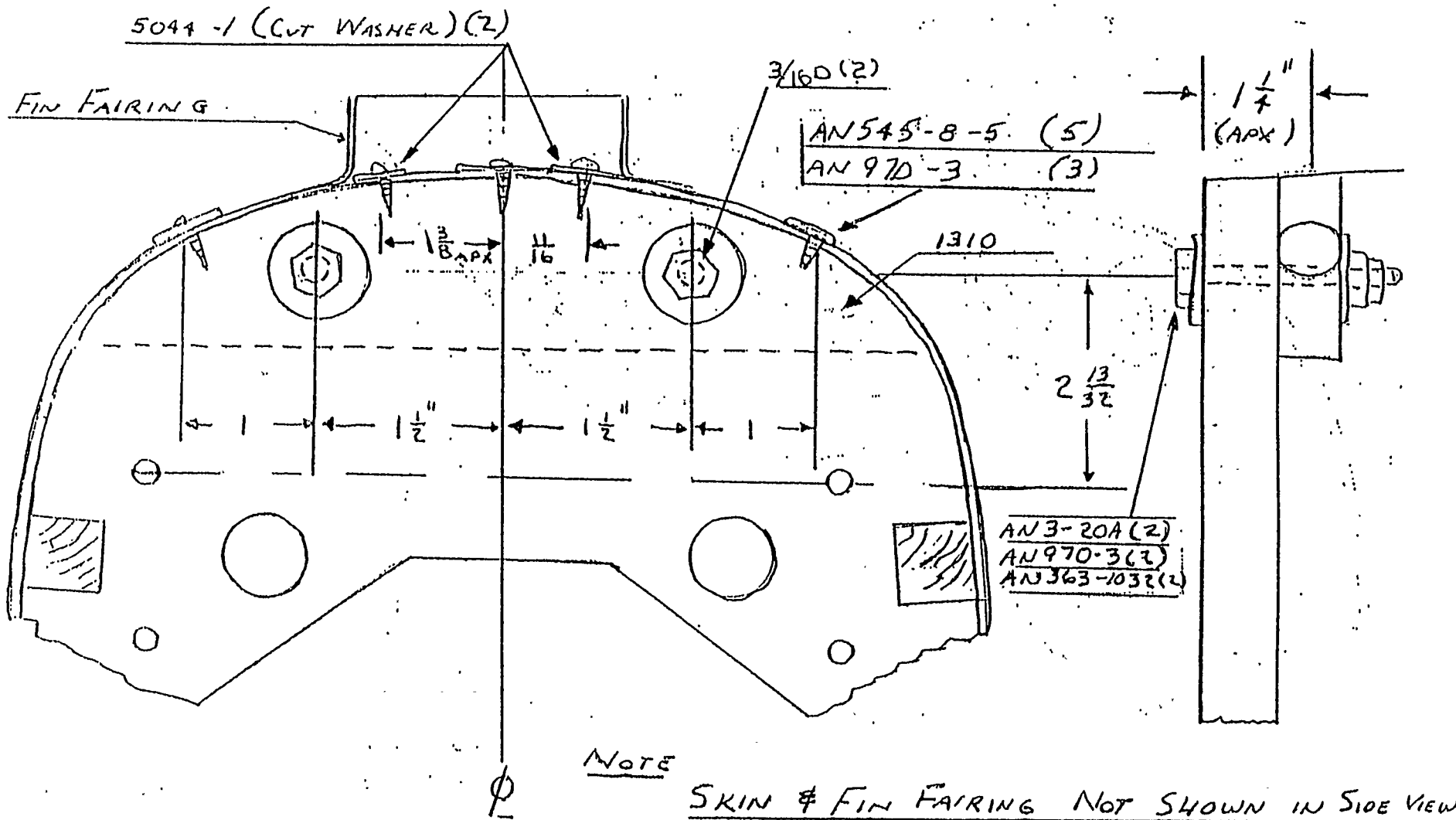

FIG. 1

NOTE: THIS DRAWING IS FOR M-18 MODELS EQUIPPED WITH THE PUSH-PULL ELEVATOR CONTROL SYSTEMS.

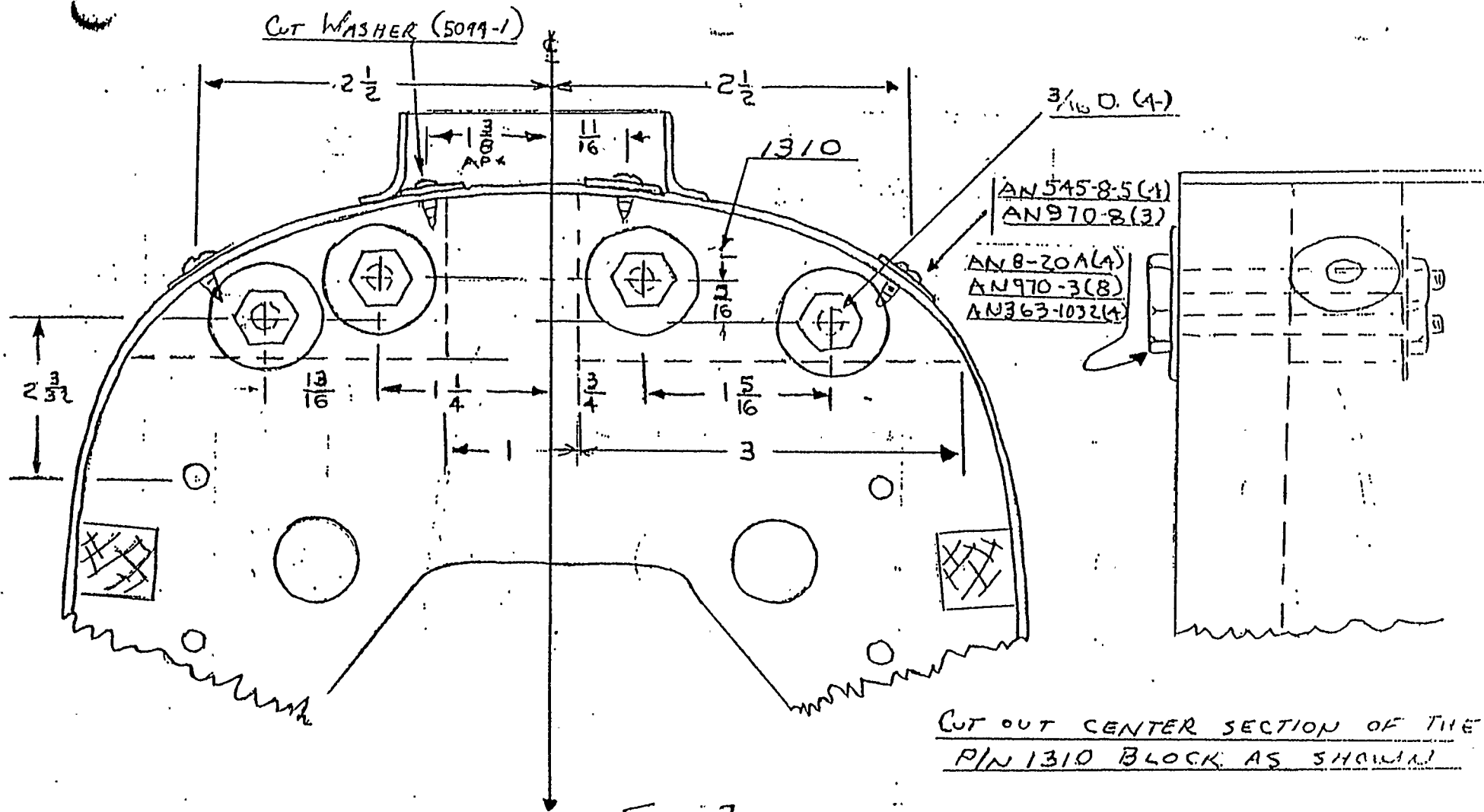

FIG. 2

NOTE:

THIS DRAWING IS FOR M-18 MODELS EQUIPPED WITH THE
CABLE ELEVATOR CONTROL SYSTEMS.

ORIGINAL
As Received By
ATP

NOTE

FOR CABLE ELEVATOR CONTROL SYSTEMS, CUT OUT UPPER FLANGE OF 1307 AS SHOWN.

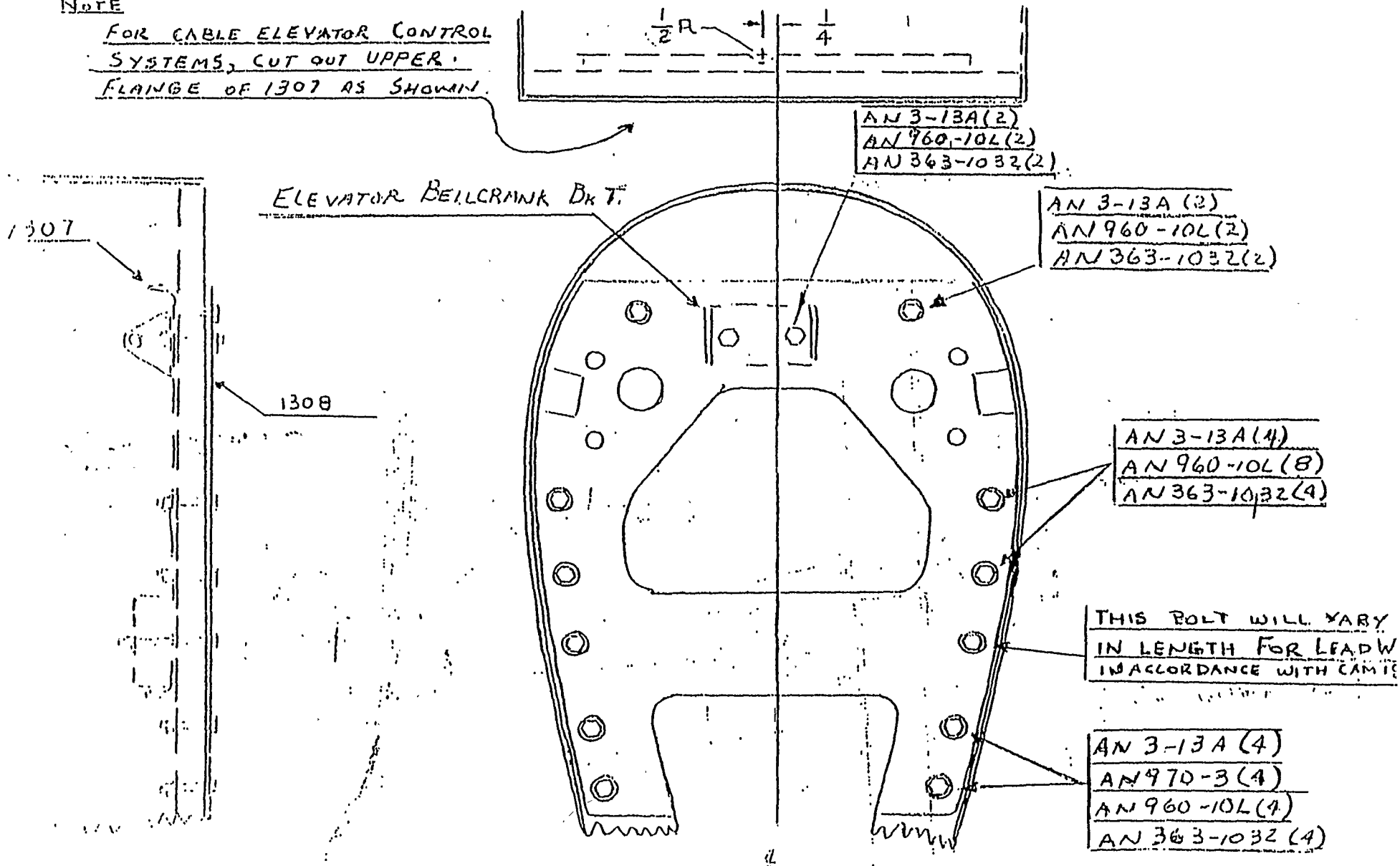
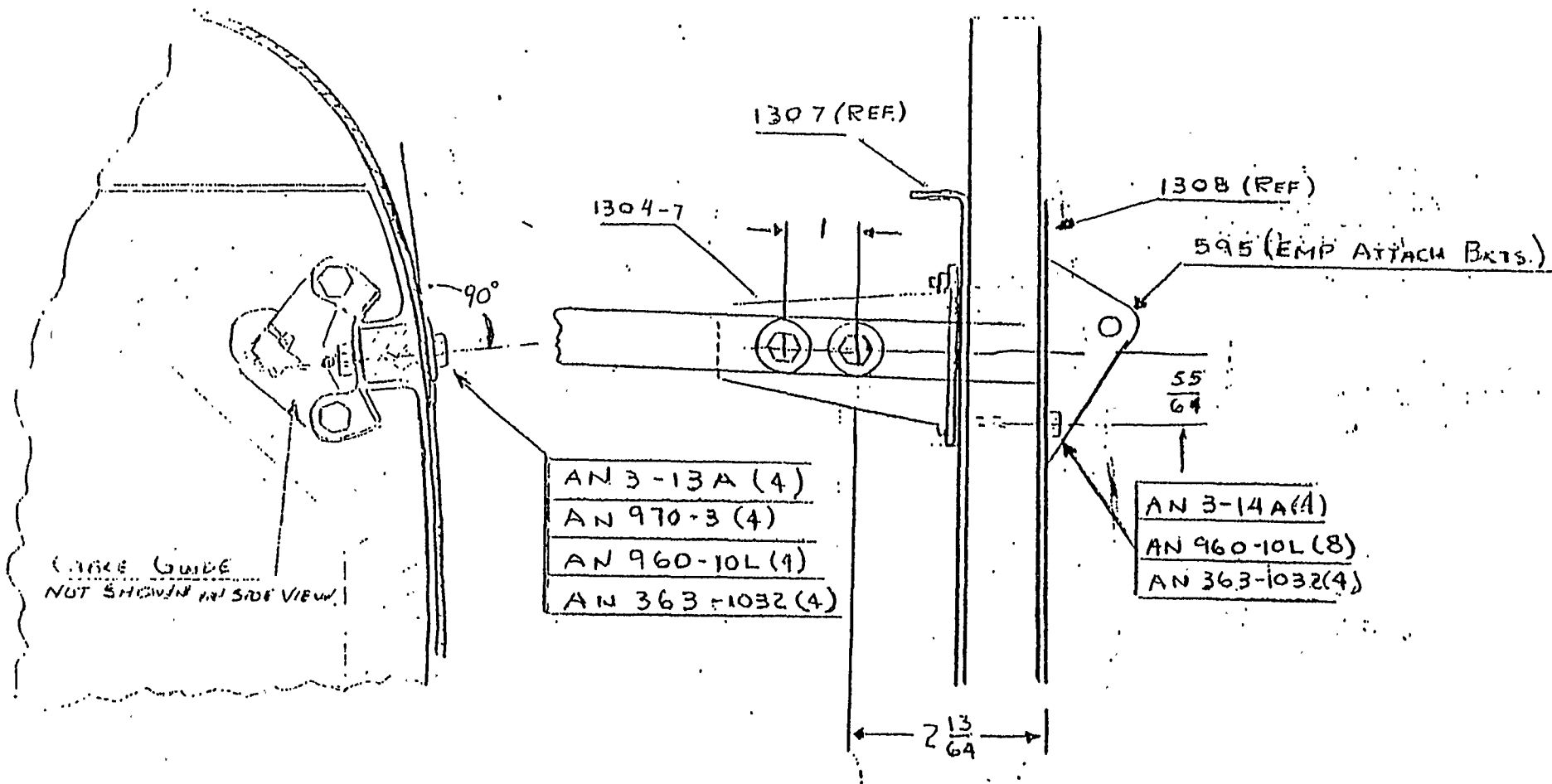

FIG. 3

**ORIGINAL
As Received By
ATP**



NOTE:
SKIN NOT SHOWN FOR CLARITY.

LEFT SIDE SHOWN

FIG. 4

ORIGINAL
As Received By
ATP

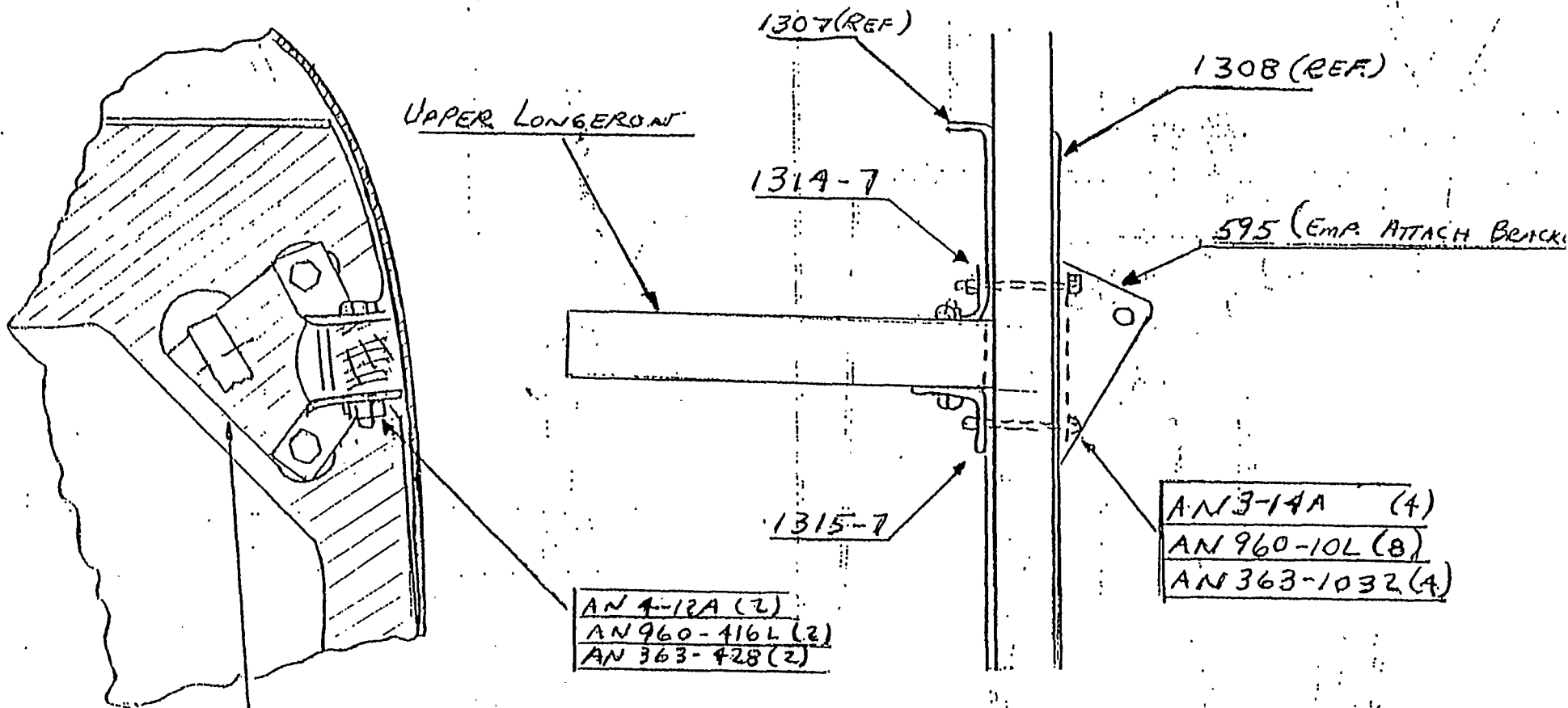

CABLE GUIDE
NOT SHOWN IN SIDE VIEW

NOTE

SKIN NOT SHOWN FOR CLARITY

FIG 5

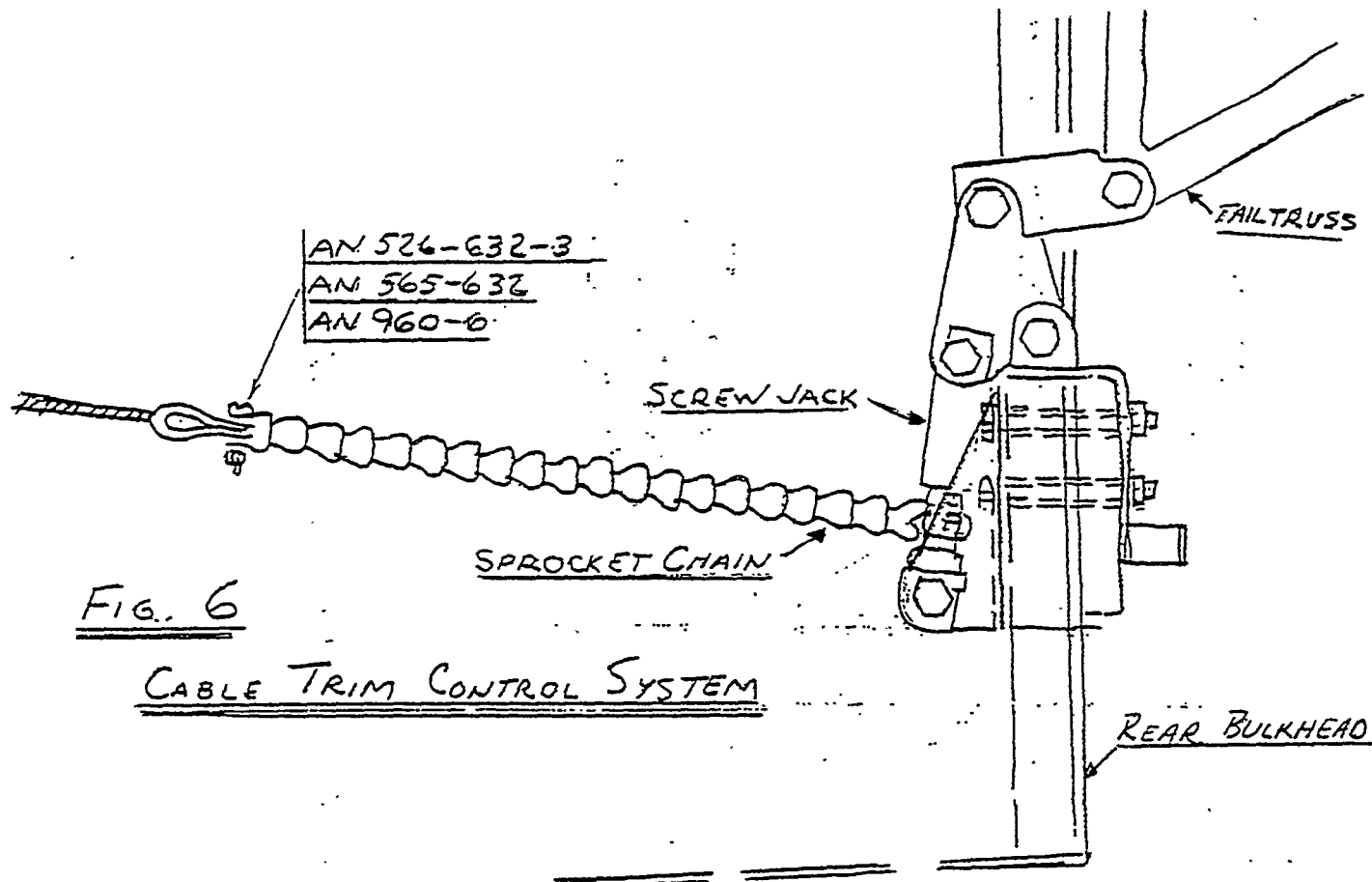

FIG. 6

CABLE TRIM CONTROL SYSTEM

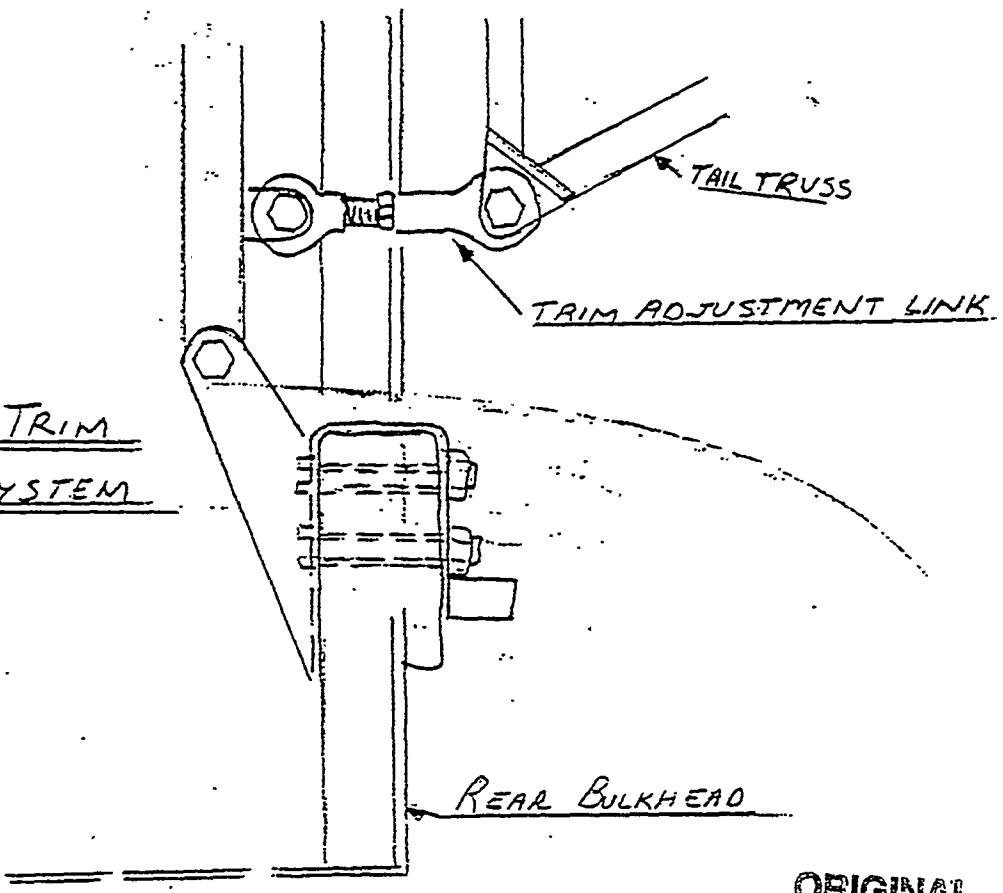

FIG 7

PUSH-PULL TRIM CONTROL SYSTEM

50-01-01

MOONEY: Applies to All Model M-18L Aircraft.

Compliance required as soon as possible but not later than next 25 hours operating time and at each 25-hour period thereafter until reinforcement of engine mount lugs is accomplished.

Inspect the four engine mount lugs for cracks. If cracks are evident, reweld the lugs to mate with the mount holes on the engine and weld an X-4130 0.058-inch strap 1/2 x 3-inches to the lug and the side tube member. Further inspections are not necessary after the above reinforcement of the lugs is made.

(Mooney Service Bulletin No. 4 covers this same subject.)

51-03-01

MOONEY: Applies to Model M-18 Series Aircraft, Serial Numbers 1 Through 82 and 201 Through 236.

Compliance required not later than March 15, 1951.

There have been reported failures of the fuel line due to vibration and relative motion between the fuel tank and the fuel shutoff valve. To preclude the possibility of recurrence of this type failure, cut the fuel line at a point approximately 4 inches from the fuel tank outlet and install a 4-inch length of 3/8-inch ID approved aromatic resistant flexible hose and hose clamps at this point.

(Mooney Service Bulletin No. 6 covers this same subject.)

53-17-01

MOONEY: Applies to All Model M-18 Series Aircraft.

Compliance required by October 15, 1953.

To prevent possible fouling of controls and the control stick by foreign objects install canvas boot P/N 22-7 around control stick and secure to floor boards. These boots are available from Mooney Aircraft, Inc., Box 72, Kerrville, Texas.

(Mooney Service Bulletin No. 11 covers this same subject.)

53-24-03

MOONEY: Applies to All Model M-18L Aircraft Which Have Not Had the Landing Gear Bellcrank Cover Installed.

Compliance required by February 28, 1954.

In order to prevent baggage from jamming or fouling the landing gear retraction bellcrank P/N 35-1, install bellcrank covers, P/N 1028-1 with installing angles P/N 1028-2.

(Mooney Service Bulletin No. 12 covers this same subject.)

59-22-03

MOONEY: Applies to All M-18 Series Aircraft.

Compliance required within the next 10 flight-hours but not later than December 15, 1959.

The following inspections, repairs, and replacements shall be accomplished:

(a) Empennage

(1) Remove and disassemble empennage. Remove control surfaces and hinge brackets from fin and horizontal stabilizer. Remove bolts through stabilizer main spar attach blocks. Disassemble stabilizer and fin from empennage truss and each other.

(2) Inspect all bolted joints for the following items:

- (i) Wear on bolts
- (ii) Wear on bolt holes in fittings and lugs
- (iii) Wear on bushing
- (iv) Wear of bushing on fittings, lugs and wood. (Replace parts as necessary).

(3) Remove all fabric from stabilizer and fin. Inspect all wood and glue joints including attachment of leading edge skin to main spar for deterioration.

(4) At center section of stabilizer spar inspect glue joint between attach blocks and spar for deterioration and inspect spar and blocks for cracks. Inspect fin spar for cracks at attach bolts.

(5) Any defective wood parts shall be replaced or repaired in accordance with CAM 18 and/or manufacturer's recommendations. When the fin and stabilizer are satisfactory, reinforcement of the stabilizer main spar center section and the fin and stabilizer center hinge rib-rear spar attachment shall be accomplished in accordance with Mooney M-18 Service Letter No. 16. (Kits of reinforcement parts are available from Mooney Aircraft, Inc.)

(6) Clean all empennage drain holes, and see that they are located as specified in Mooney M-18 Service Letter 16.

(7) Inspect welds at rudder and elevator hinges and control horns and at all joints on the tail truss for inadequate welds (i.e. weld which does not fill fillet cross section area) and for cracks using either method (i) or (ii) below.

(i) Magnetic particle or X-ray inspection.
(ii) Remove paint and primer and visually inspect welds with a 10-power glass. Parts with defective welds are to be replaced or repaired. A joint may be rewelded providing the old weld is removed and the surfaces thoroughly cleaned.

(8) Remove upper tail truss attach fittings from aft fuselage bulkhead and inspect as described in item (2). Inspect bulkhead front and back for cracks in area of these fittings. Inspect glue joint between bulkhead and aft fuselage skin and longerons for deterioration or separation. Repair in accordance with Mooney M-18 Service Letter No. 17. Examine trim linkage attached to lower part of aft bulkhead for worn bolts. Replace bolts as necessary.

(9) Reassemble and install empennage making sure all bolts are tight. Block airplane solidly at tail skid and inspect for empennage play as follows:

(i) Stabilizer - Move up and down at one tip and measure at opposite tip. Total allowable play 1/2-inch up and down.

(ii) Stabilizer - Move fore and aft at one tip and measure at opposite tip. Total allowable play 3/4-inch fore and aft.

(iii) Fin - Move fore and aft at top leading edge and measure at bottom rudder trailing edge. Total allowable play 1/2-inch up and down.

(b) Aft Fuselage

(1) Inspect wood around forward fuselage tubular structure attach fittings for deterioration. Clean all drain holes. Inspect all glue joints for deterioration. See that drain holes are located as specified in Mooney M-18 Service Letter 16.

(c) Wing

(1) Remove-seat, auxiliary fuel tank and belly access panel. Inspect ribs, skin and both spars at lower center section and around fuselage fittings for wood and glue joint deterioration.

(2) Inspect all wood and glue joints in wheel well area for deterioration. Inspect both spars for cracks in area of the gear attachments.

(3) Inspect interior of wing in areas having access openings.

(4) Remove aileron and inspect hinges and control horn in accordance with part (a), item (7).

(5) Remove wing fabric locally in area of aileron hinges and at inboard corner of aileron cutout and check condition of wood and glue joints. If evidence of deterioration is found remove fabric further as necessary for complete examination of forward area of wing trailing edge. Check security of attachment of wing trailing edge in aileron area.

(6) Clean all drain holes in wing, and see that they are located as specified in Mooney M-18 Service Letter 16.

(d) Control Systems

(1) Inspect all control systems (aileron, trim, rudder, and elevator).

(i) Visually inspect all welds for cracks and inadequate welds (i.e. weld which does not completely fill fillet cross section area).

(ii) Check security of all bolted hinge and fitting attach points.

(Mooney M-18 Service Letters Nos. 16 and 17 pertains to this same subject.)

79-11-05 R1 MOONEY: Amendment 39-3480 as amended by Amendment 39-4050. Applies to Mooney M-18L S/N's 2 and up, M-18C S/N's 201 and up, M-18LA S/N's 100 through 200, M-18C55 S/N's 323 and up certificated in all categories.

Compliance required as indicated:

To prevent failure of the vertical fin spar in flight due to wood deterioration and to detect other wood and glue joint deterioration in the wood wing and wood empennage structure, accomplish the following inspections and checks or approved equivalents within the next 30 days after the effective date of this AD, unless already accomplished within the last 35 months, and thereafter at intervals not to exceed 36 months from the last inspection:

(1) Remove all fabric from the horizontal and vertical stabilizers. Inspect all wood and glue joints including attachment of leading edge skin to main spar for deterioration.

(2) At center junction of stabilizer spar and fin inspect glue joint between attach blocks and stabilizer spar for deterioration and inspect spar and blocks for cracks. Inspect fin and spar for cracks at attachment bolts.

(3) Inspect rear bulkhead of the stabilizer for cracks and looseness in the area of the stabilizer attachments. Inspect attachment blocks for cracks or looseness at spar.

(4) Remove wing fabric locally in area of aileron hinges and at inboard corner of aileron cutout. Check condition of wood and glue joints. If evidence of deterioration is found, remove fabric further as necessary for complete examination of forward area of wing trailing edge. Check attachment of wing trailing edge in aileron area for looseness.

(5) Ensure that all drain holes in empennage and wing are clear.

(6) If any defects set forth in paragraphs (1), (2), (3), or (4) above are detected, repair in accordance with FAA Advisory Circular AC 43.13-1A or approved equivalent or replace with an identical new part or equivalent prior to further flight. Equivalent repairs, inspections, and/or parts must be approved by the Chief, Engineering and Manufacturing Branch, FAA, Eastern Region.

(7) A borescope, utilizing FAA approved permanent access holes, is considered an approved equivalent means of inspection only for the vertical and horizontal stabilizers, when satisfying the requirements of paragraphs (1), (2), and (3). The borescope inspection shall be accomplished within the next 30 days after the effective date of this AD, unless already accomplished within the last 11 months, and thereafter at intervals not to exceed 12 months from the last inspection.

(8) Upon submission of substantiating data by an owner or operator, through an FAA maintenance inspector, the Chief, Engineering and Manufacturing Branch, FAA, Eastern Region, may adjust the inspection time in this Airworthiness Directive.

Amendment 39-3480 was effective June 5, 1979.

This amendment 39-4050 is effective April 1, 1981.

79-18-07

MOONEY: Amendment 39-3547. Applies to Mooney Mite

Models M-18L S/N's 2 and up, M-18C S/N's 201 and up, M-18LA S/N's 100 through 200, M-18C55 S/N's 323 and up, certificated in all categories.

Compliance required as indicated:

To prevent failure of structural areas due to wood deterioration and to detect other wood and glue joint deterioration in the fuselage and wood wing, accomplish the following within the next 30 days after the effective date of this AD, unless already accomplished within the last 35 months, and thereafter at intervals not to exceed 36 months from the last inspection.

(1) Remove the fabric inboard of station 12 on both wings over the main and auxiliary wing spars. Inspect spars for cracks and delaminations especially at all bolt hole locations and in the area of the landing gear attachments.

(2) If not already provided, apply a water resistant cloth or plastic adhesive such as duct tape at the wing to fuselage joint from the wing leading edge to the wing trailing edge under the metal fairing strip, to prevent entry of water at this point.

(3) Inspect all wood and glue joints in the wheel well area for cracks and wood deterioration.

(4) Remove fabric between fuselage stations 29 to 35.5. Inspect plywood joints for wood deteriorations.

(5) Apply hand pressure on top of plywood turtleback in the area of fuselage station 105. If softness is detected, remove fabric and inspect for wood cracks.

(6) Inspect welds for cracks and welds which do not completely fill fillet cross section area at rudder and elevator hinges and control horns with a 10-power glass.

(7) Inspect the fuel tank attachment points to the fuselage in the areas of the attachment bolts for deterioration.

(8) Inspect glue joints in the area of the battery for separation and deterioration.

(9) Clear all drain holes in fuselage.

(10) If any defects noted in paragraphs (1) through (8) above are detected, repair in accordance with FAA Advisory Circular AC 43.13-1A or approved equivalent, or replace with an identical new part or equivalent, prior to further flight. Equivalent repairs or parts must be approved by the Chief, Engineering and Manufacturing Branch, FAA, Eastern Region.

(11) Upon submission of substantiating data by an owner or operator through an FAA Maintenance Inspector, the Chief, Engineering and Manufacturing Branch, FAA, Eastern Region, may adjust the inspection time in this airworthiness directive.

This amendment is effective September 3, 1979.